

# KOMATSU

## WA800-3

## WA900-3

### ENGINE POWER

WA800-3: 636 kW / 853 HP @ 2.000 rpm

WA900-3: 672 kW / 901 HP @ 2.050 rpm

### OPERATING WEIGHT

WA800-3: 104.500 kg / WA900-3: 107.350 kg

### BUCKET CAPACITY

WA800-3: 10 - 14 m<sup>3</sup> / WA900-3: 11,5 - 13 m<sup>3</sup>

**WA**  
**800**  
**900**

WHEEL LOADER



**WA800-3 / WA900-3**

# WALK-AROUND

## Komatsu-integrated design

For the best value, reliability, and versatility. Hydraulics, power train, frame, and all other major components are engineered by Komatsu. You get a machine with components that are designed to work together to deliver higher production levels, greater reliability, and more versatility.

## Standard, high-lift and Load & Carry booms

are available in order to suit your application.

	Standard	High-Lift	Load & Carry
WA800-3	✓	✓	✓
WA900-3	✓	✓	-

## High productivity and fuel efficiency

- High performance SAA12V140E-3 engine
- Low fuel consumption
- Dual-mode engine power select system
- Automatic transmission with shift timing select system
- Superior dumping height and reach

## A full range of buckets and wear parts



## Harmony with the environment

- Meets EPA Tier II emission regulations
- Low sound levels
- High fuel efficiency

**ENGINE POWER**

WA800-3: 636 kW / 853 HP

WA900-3: 672 kW / 901 HP

**OPERATING WEIGHT**

WA800-3: 104.500 kg

WA900-3: 107.350 kg

**BUCKET CAPACITY**WA800-3: 10 - 14 m<sup>3</sup>WA900-3: 11,5 - 13 m<sup>3</sup>**Excellent operator comfort**

- Advanced Joystick Steering System (AJSS) control
- Electronically controlled ECMV automatic transmission
- Low sound levels
- Electronically controlled transmission lever
- Pillar-less large cab with ROPS/FOPS canopy

**Easy maintenance**

- Simple and fast maintenance
- VHMS (Vehicle Health Monitoring System)
- Rear access stairs
- Automatic central lubrication system (optional)

**Excellent reliability and durability**

- Reliable original Komatsu components
- Robust torsionally resistant frame
- Maintenance-free fully hydraulic wet disc brakes
- Sealed DT wiring harness connectors
- Flat face-to-face O-ring seals

# HIGH PRODUCTIVITY AND FUEL EFFICIENCY

Komatsu's integrated design results in components that are matched to provide the most efficient use of power, whether you're excavating or stock handling.

## Engine

The Komatsu SAA12V140E-3 delivers the power and efficiency to get the job done quickly and cost-effectively. It's a water-cooled, four-stroke cycle, 12-cylinder, turbocharged, air-to-air after cooled, common rail direct injection engine with a piston displacement of 30,5 litres that produces high performance and excellent fuel economy.

## Protecting the environment

The engine meets EPA Tier II emissions regulations without sacrificing power or machine productivity.

## Low fuel consumption

Low fuel consumption is achieved because of the low-noise, high-torque engine and the large-capacity torque converter with maximum efficiency in the low-speed range.

## Excellent stability

The widest tread in their class and a long wheelbase provide maximum machine stability.



## Two stage hydraulics

The machine is equipped with a two mode active working system, a great improvement on the already well received two stage hydraulic system.

This system provides the most efficient hydraulic flow for your operation. The active working switch has two modes: powerful loading or normal loading. In powerful loading mode hydraulic flow towards the work equipment can be increased and reduced as and when required. In normal loading mode all hydraulic flow is transferred directly to the work equipment.

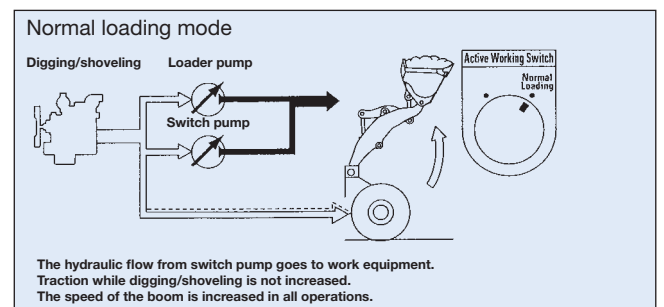
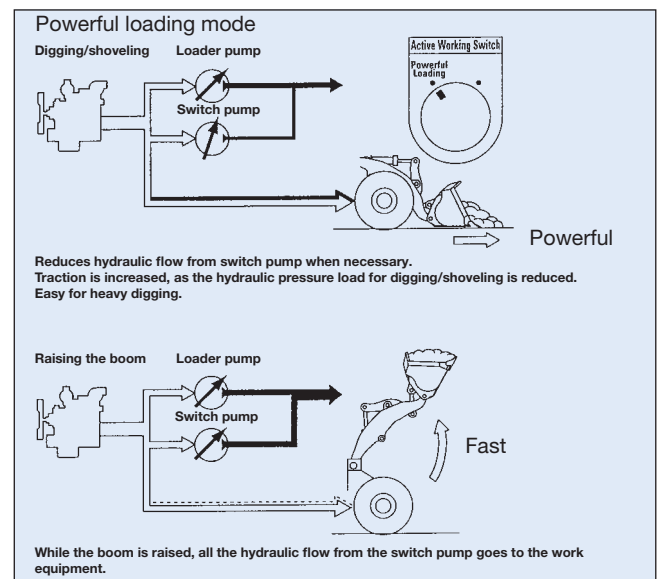

# MACHINE MATCHING SOLUTIONS

## Easy loading

The WA800-3 & WA900-3 have been designed in order to provide a choice of machine, bucket size and boom to suit our customers loading and excavating requirements. Depending on the buckets used and the application, the WA800-3 & WA900-3 can load the following machines thanks to their superior reach and clearance.

## Thinking together

With its complete range of loading and hauling machines, Komatsu is able to offer several machine matching solutions with the goal of increasing your production and bottom line. Using our Optimum Fleet Recommendation or 'OFR' program, Komatsu has qualified production and application specialists available throughout Europe, willing to recommend and assist customers with detailed evaluations of their applications. Please contact your nearest Komatsu distributor for more information.

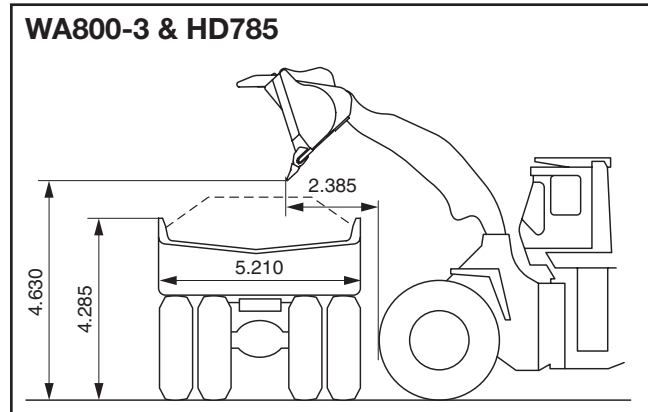

The HD785 (91 metric tonnes maximum payload) can be loaded in 5 to 6 passes by the WA800-3.

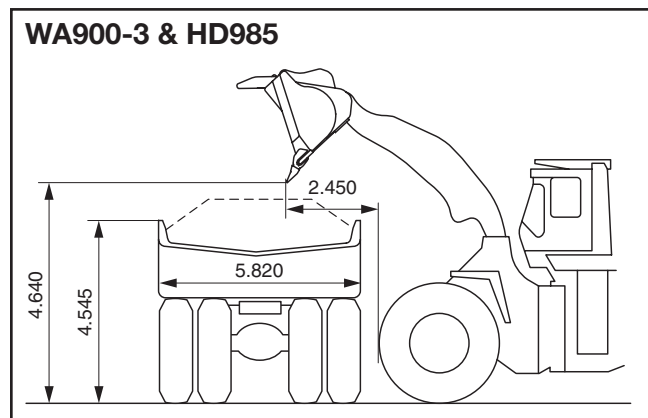

The HD985 (105 metric tonnes maximum payload) can be loaded in 4 to 5 passes by the WA900-3.



# EXCELLENT OPERATOR COMFORT



## Low noise design

The noise levels are substantially reduced. Engine compartment noise isolation plus the specially designed low speed radiator cooling fan give reduced noise levels.

## Air-suspended seat

Easy adjustable to give the operator a maximum of flexibility and comfort.



## Two-door, walk-through cab

Komatsu is offering the safest cabin on the market, with an easy entry and exit from both sides of the cab.

## Cabin damper mounting for low vibration levels

The silicone oil filled rubber mounts result in reducing the fatigue caused by mechanical vibrations and noise. This helps the operator to remain productive the whole day. It also increases the lifetime of all operator compartment components.



## Pillar-less large cab

A wide pillar-less windscreen provides excellent front visibility. The wiper arm covers a large area to provide great visibility even on rainy days. The cab area is the largest in its class providing maximum space for the operator.



### Advanced Joystick Steering System (AJSS) control

This system provides a precise steering operation that's sometimes needed on narrow, long quarry roads. The joystick steering is also ideal in V-shape cycle loading.



### Steering wheel with telescopic/tilt column

As an alternative to the AJSS system, a steering wheel is also available. The operator can tilt and telescope the steering column to provide a comfortable working position.



### Variable transmission cut-off system

The operator can set the transmission cut-off pressure desired for the left brake pedal using the switch located on the right-side control panel. The operator can improve the working performance by setting the cut-off pressure properly depending on working condition.

- High cut-off pressure for digging operations.
- Low cut-off pressure for truck-loading operations



1. T/M cut-off ON/OFF switch  
2. T/M cut-off set switch



### Automatic transmission with ECMV

The automatic transmission with ECMV automatically selects the proper gear speed based on travel speed, engine speed, and other travel conditions. The ECMV (Electronically Controlled Modulation Valve) system engages the clutch smoothly to prevent lags and shocks when shifting. This system provides efficient machine operation and a comfortable ride.

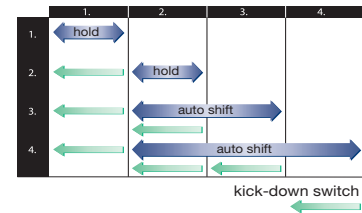

The ECMV (Electronically Controlled Modulation Valve) system engages the clutch smoothly to prevent lags and shocks when shifting. This system provides efficient machine operation and a comfortable ride.

- Kick-down switch: With the touch of a finger, the kick-down switch automatically downshifts from second to first when beginning the digging cycle. It automatically shifts up from first to second when the direction control lever is placed in reverse. This results in increased rim pull for better bucket penetration and reduced cycle times for higher productivity.

- Hold switch: Auto shift is selected and if the operator turns on this switch when the lever is in 3rd or 4th gear, the transmission is held in that gear speed.



1. Kick-down switch  
2. Hold switch

### Remote boom positioner

The highest and lowest position of the bucket can be set from the cab to match any truck body. Once the positioner is set, the bucket stops smoothly at the required position.

## EASY MAINTENANCE

### Service with a smile

It would be better if most of us approached routine maintenance and service as something that made us smile. That's why Komatsu designed the WA800-3 and WA900-3 wheel loaders to make servicing as easy as possible. We know that by doing this, routine maintenance and servicing are less likely to be skipped, which can mean a reduction in costly downtime later. Here are some of the many service features found on these machines:



- Large service doors provide easy access to all engine service points and filters, and can be locked with the ignition key.
- Ground level greasing: all grease points are easily reached from ground level and grease banks are provided in strategic areas to reduce maintenance time.
- Large platforms provide easy access to cab windows.
- Full-hydraulic service and parking brakes eliminate air system maintenance.
- Cylinder buffer rings reduce shock loads to the cylinder packing and prolong cylinder life by 30%.
- Optional automatic lubrication system and wiggins fast fuel system are available to reduce maintenance time.

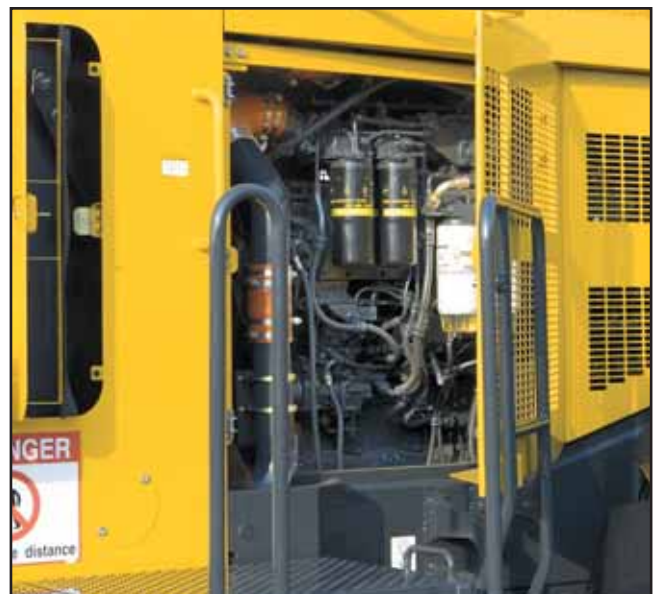

**The EDIMOS II instrument gauge cluster display**

The maintenance monitor panel shows all machine functions and systems, which are only a glance away on the side panel.



**Wet multi-disc service brakes (front and rear)**

Fully sealed. Contaminants are kept out, reducing wear and maintenance. Brakes re-

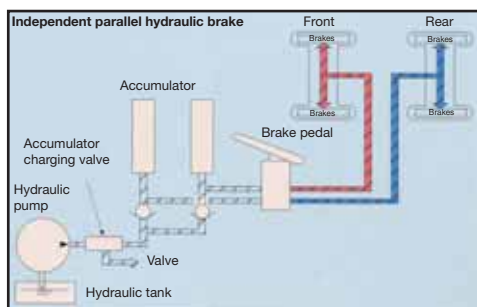

quire no adjustments for wear, further reducing maintenance costs. There is no air system to bleed, which eliminates the condensation of water in the system that can lead to contamination and corrosion. The braking system's reliability has been increased with the use of two independent hydraulic circuits, providing hydraulic backup in the event that one circuit fails.

**VHMS (Vehicle Health Monitoring System)**

The VHMS controller monitors the health conditions of major components and enables analysis of the machine and its operations. The VHMS controller monitors and stores all data received from the engine and transmission controller and various additional sensors on the major components. This way, it's possible to record the evolution of the machine's health condition. This data can be downloaded via a portable computer or via satellite communication (option). In both cases, Komatsu specialists can analyse this downloaded data and follow up trends in the machine's condition. When using the optional satellite communications, the Komatsu specialist can inform you whenever an abnormal condition occurs. This way, repair and maintenance costs can be optimised, and maximum machine availability can be maintained.

**Spin-on filters**

Easily accessible lubrication points reduce maintenance time and the change of maintenance items.

**Gear pump-driven forced lubrication**

System has full flow filtration whilst all fuel and oil filters are spin-on for easy maintenance.

**Rear access stairs**

For all access and egress to the machine, a rear access stair with safety rail is provided. The step width, clearance, and step angle have been designed with the operator's safety in mind. A step light provides light for night boarding.

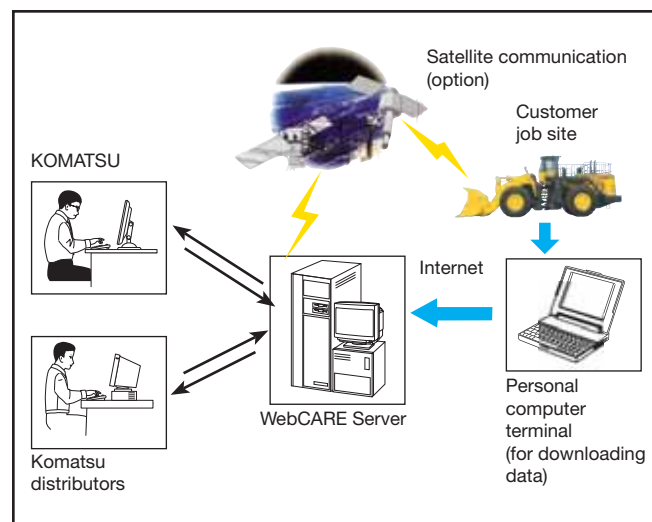

# HIGH RELIABILITY AND DURABILITY

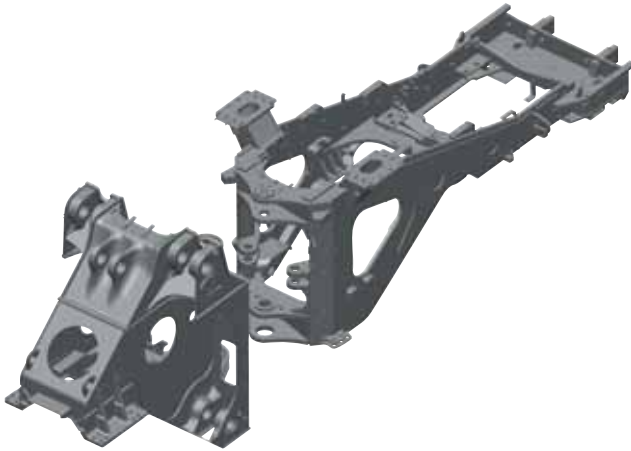

## High-rigidity frames and loader linkage

The front and rear frames and loader linkage have more torsional rigidity providing longer frame life. Extensive testing has proved that frame and loader linkage have the ability to accommodate actual work loads.

## Sealed DT connectors

Main harnesses and controller connectors are equipped with sealed DT connectors providing high reliability, water and dust resistance.



## Flat face-to-face O-ring seals

Flat face-to-face O-ring seals are used to securely seal hydraulic hose connections and to prevent oil leakage. In addition, buffer rings are installed on the head side of the all-hydraulic cylinders to lower the load on the rod seals and maximise reliability.

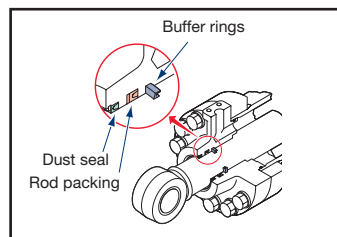
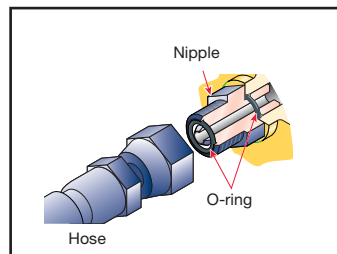

## Komatsu components

Komatsu manufactures the engine, torque converter, transmission, hydraulic units, and electric parts on these wheel loaders. Komatsu wheel loaders are manufactured with an integrated production system using a strict quality control.

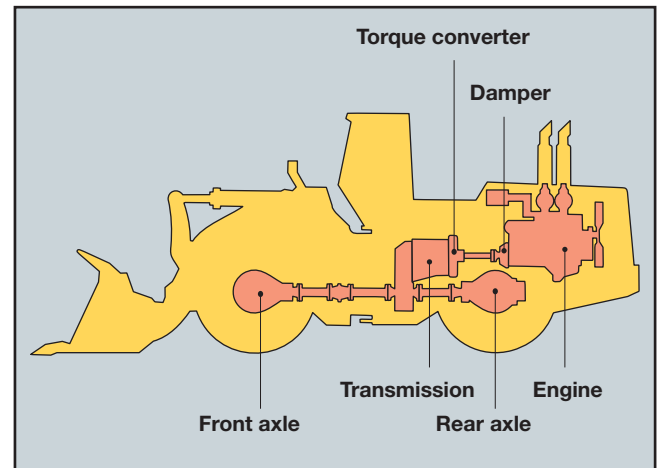

## Komatsu designed axles and final drives

Provide rugged reliability with low maintenance. Axle shafts are full-floating. The front axle is fixed, whilst the rear axle is a centre pin support design that provides a total oscillation of up to 22 degrees. The differential reduction gear is a heavy-duty spiral bevel gear, for strength and reliable performance. The rugged, outboard planetary final drives carry the total gear reduction of the drive train to the wheel, which is mounted to the axle hub.

## Engine pre-lube system

Durability of the engine is improved by raising the engine oil pressure before starting the engine. When the operator turns the key, the pre-lubrication pump sends oil from the engine oil pan to the engine oil filter and raises the pressure of that oil to the set pressure. Then, the starting motor rotates to start the engine.

# SERVICEABILITY AND CUSTOMER SUPPORT

## The Komatsu dealer network guarantees you the lowest operating costs

When you purchase Komatsu equipment, you gain access to a broad range of programmes and services that have been designed to help you get the most from your investment. These all support substantial productivity, long and useful equipment lifetime, low operating costs, and a high trade-in or resale value.

- Many of the vital components of the WA800-3 and WA900-3 have been installed and proven totally reliable in other heavy-duty Komatsu earthmoving equipment.
- Komatsu's extensive parts warehouses and logistics system across Europe and around the globe ensure unparalleled parts availability.
- Continuous training programmes for Komatsu service personnel guarantee that your equipment is serviced properly and maintained in top running condition.
- The Komatsu Oil Wear Analysis (KOWA) programme offers sophisticated oil analysis to identify problems to be followed up during preventative, scheduled maintenance.
- KFWP (Komatsu's Flexible Warranty Programme) is available, providing a range of extended warranty options on the machine and its components. These can be chosen, based on individual needs and activities.  
This programme is designed to help reduce total operating costs.
- A Komatsu Repair & Maintenance Contract is a way to establish a fixed operating cost and ensure optimal machine availability for the duration of the contract.



# BUCKETS AND CUTTING TOOLS



## Universal buckets

This type of bucket with a long, flat bucket floor features an outstanding material retaining capacity. The universal bucket can be equipped with a V-shaped edge, bolt on edge or flush mount adapters and interchangeable Kmax™ teeth.



## Rock buckets

Buckets with capacities up to 14 m<sup>3</sup> are available for rock applications. The trapezoidal form supports outstanding material penetration. Welded or bolted wear plates made of abrasion resistant steel ensure a long service life. Stone deflectors are standard. All bucket areas in contact with the material are made of Hardox 400 or better steel.



## Heavy duty rock buckets

The ideal bucket for hard abrasive rock conditions. Increase profits by protecting the bucket investment and reduce repair works. Komatsu offers total bucket protection by using highly wear resistant exchangeable parts. A bolt on teeth system reduces welding on the bucket and prevents loss of teeth.



## Extra heavy-duty rock buckets with K VX™ teeth

XHD rock buckets with K VX™ teeth as well as bolt on segments are available for highly abrasive materials. This extremely durable system as well as the standard stone deflectors guarantee maximum service life even under the most severe operating conditions. A bolt on teeth system reduces welding on the bucket.



## Ultra-wear resistant ground engaging equipment – Lower costs per tonne

With the brands Komatsu K VX™, Kmax™ and Hensley™-Parts, Komatsu has extensive know-how, making it a leading supplier of GET in the global market. The comprehensive range of ultra-wear resistant teeth, segments and wear plates covers all applications even under the toughest working conditions.

# SPECIFICATIONS



## ENGINE

Model .....Komatsu SAA12V140E-3  
 Type.....Water-cooled, 4-stroke, turbocharger, aftercooled  
 Engine power at rated engine speed  
 WA800-3 (ISO 14396) ..... 636 kW / 853 HP @ 2.000 rpm  
 WA800-3 (ISO 9249) ..... 603 kW / 809 HP @ 2.000 rpm  
 WA900-3 (ISO 14396) ..... 672 kW / 901 HP @ 2.050 rpm  
 WA900-3 (ISO 9249) ..... 638 kW / 856 HP @ 2.050 rpm  
 Max. torque / engine speed  
 WA800-3.....3.727 Nm / 1.400 rpm  
 WA900-3.....4.089 Nm / 1.300 rpm  
 No. of cylinders ..... 12  
 Bore x stroke.....140 x 165 mm  
 Displacement.....30,48 ltr  
 Governor ..... Mechanical, all speed  
 Injection system ..... High pressure direct injection  
 Lubricating system ..... Gear pump  
 Air-filter type ..... Dry type with dust indicator  
 and auto dust evacuator



## TRANSMISSION

Torque converter .....One-stage, one-phase, 3-element  
 Transmission..... Full-powershift, planetary gear

Travel speeds			
Gear	1.	2.	3.
Forwards	7,0 km/h	12,3 km/h	28,0 km/h
Backwards	7,1 km/h	12,4 km/h	28,3 km/h

WA800-3: 45/65-45-46 PR L5 tubeless tyre

WA900-3: 45/65-45-58 PR L5 tubeless tyre



## AXLES AND FINAL DRIVES

System ..... 4-wheel drive  
 Front axle..... HD axle, fixed, full-floating  
 Rear axle ..... HD axle, full-floating, 22° swing angle  
 Reduction gear ..... Spiral bevel gear  
 Differential gear ..... Straight bevel gear  
 Final drive ..... Planetary gear, single reduction



## SERVICE REFILL CAPACITIES

Cooling system.....337 ltr  
 Fuel tank..... 1.555 ltr  
 Engine oil..... 130 ltr  
 Hydraulic system.....725 ltr  
 Axle (both front and rear axle) .....720 ltr  
 Torque converter and transmission ..... 140 ltr  
 Brake tank ..... 31 ltr



## BRAKES

Operating brakes.....Hydraulically actuated, wet multi-disc brakes  
 on all wheels  
 Parking brake ..... Dry-disc, hydraulically-released,  
 spring applied on front axle drive shaft  
 Emergency brake ..... Uses the parking brake



## HYDRAULIC SYSTEM

Circulating capacities  
 Loader pump (WA800-3) .....405 ltr/min  
 Loader pump (WA900-3) .....415 ltr/min  
 Switch pump (WA800-3).....405 ltr/min  
 Switch pump (WA900-3).....415 ltr/min  
 Steering pump (WA800-3) .....307 ltr/min  
 Steering pump (WA900-3) .....315 ltr/min  
 Working pressure (relief valve setting) (WA800-3) .....31,4 MPa  
 Working pressure (relief valve setting) (WA900-3) .....34,3 MPa  
 Control valve hydraulics .....2-spool  
 No. of boom/bucket cylinders.....2/1  
 Bore diameter x stroke  
 Boom cylinder.....260 x 1.368 mm  
 Bucket cylinder .....300 x 906 mm  
 Hydraulic control lever positions  
 Boom .....Raise, hold, lower, and float  
 Bucket..... Tilt back, hold and dump  
 Hydraulic cycle with rated load bucket filling  
 Stroke time (raise time) ..... 11,2 s  
 Lowering time (empty) ..... 4,8 s  
 Dumping time ..... 2,0 s



## STEERING SYSTEM

System .....Articulated frame steering  
 Type ..... Completely hydraulic power steering  
 Steering angle to either side.....40°  
 No. of steering cylinders ..... 2  
 Bore diameter x stroke..... 160 x 503 mm  
 Smallest turn (centre of tyre) ..... 9.200 mm



## ENVIRONMENT

Engine emissions ..... Fully complies with EPA Tier 2  
 exhaust emission regulations

# DIMENSIONS AND PERFORMANCE FIGURES

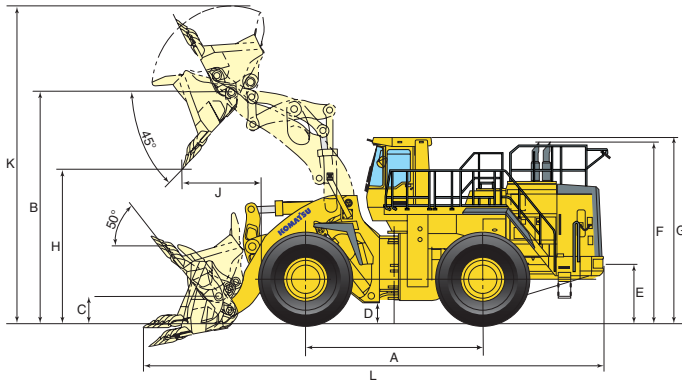

Dimensions			
		WA800-3	WA900-3
	Tread	3.350 mm	3.350 mm
	Width over tyres	4.585 mm	4.585 mm
A	Wheelbase	5.450 mm	5.450 mm
B	Hinge pin height, maximum height	6.785 mm	6.960 mm
C	Hinge pin height, carry position	850 mm	800 mm
D	Ground clearance	550 mm	550 mm
E	Hitch height	1.390 mm	1.300 mm
F	Overall height, exhaust stack	5.130 mm	5.130 mm
G	Overall height, ROPS cab	5.275 mm	5.275 mm

All measurements are for a WA800-3 with 45/65-45-46 PR L5 tyres and a WA900-3 with 45/65-45-58 PR L5 tyres.

Measurements and working specifications		WA800-3			
		Standard Boom		High-lift Boom	Load & Carry Boom
Boom		Excavating spade nose	Stock handling spade nose	Spade nose	Spade nose
Bucket type		with tip type teeth	with teeth	with teeth	with tip type teeth
Bucket capacity, heaped (ISO 7546:1983)	m <sup>3</sup>	11,0	12,3	10,0	14,0
Bucket capacity, struck	m <sup>3</sup>	9,3	10,4	8,5	11,5
Bucket width (excluding tyre protectors)	mm	4.810	4.810	4.810	5.090
Bucket weight	kg	11.430	12.150	10.750	12.080
Static tipping load, straight	kg	61.090	60.320	58.710	68.860
Static tipping load, 40° articulated	kg	53.740	52.970	51.640	60.660
H Dump clearance, maximum height and 45° discharge angle (at end of tooth)	mm	4.630	4.252	5.210	3.820
J Reach at maximum height and 45° discharge angle	mm	2.385	2.495	2.315	2.690
Reach with boom horizontal and bucket level	mm	4.360	4.510	5.010	4.550
K Operating height, fully raised	mm	9.300	9.430	9.625	8.740
Breakout force	kgf	69.000	64.170	71.790	67.000
Digging depth, when digging angle 0°	mm	165	165	200	200
Digging depth, when digging angle 10°	mm	605	630	620	670
Operating weight	kg	101.900	102.620	103.420	104.500
L Overall length	mm	13.690	14.110	14.695	13.685
Turning radius, outside corner of bucket	mm	10.940	10.965	11.100	11.020
Turning radius, center of tyre	mm	9.200	9.200	9.200	9.200

- Specifications and ratings conform to all applicable standards recommended by the Society of Automotive Engineers. SAE standard J732c, J742b and ISO 7546:1983.
- Static tipping load and operating weight shown include 45/65-45-46 PR L5 (WA800-3) / 45/65-45-58 PR L5 (WA900-3) tyres, enclosed cab, ROPS canopy, lubricant, full fuel tank, optional counterweight, and operator.
- Machine stability and operating weight are affected by counterweight, tyre size, and other weight changes to operating weights and static tipping load.

## BUCKET SELECTION GUIDE

### WA800-3

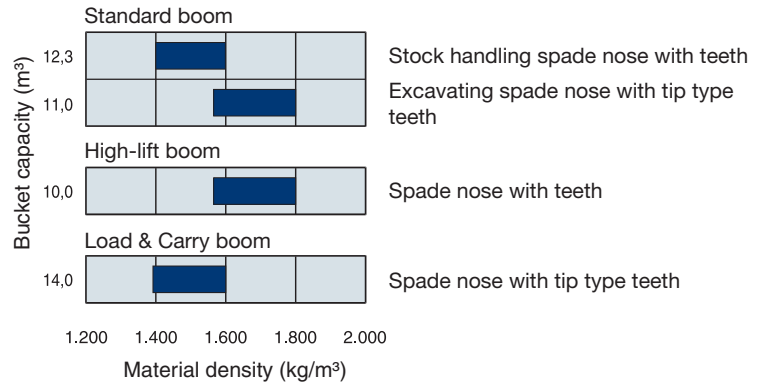

WA900-3	
Standard Boom	High-lift Boom
Excavating spade nose	Excavating spade nose
with tip type teeth	with tip type teeth
13,0	11,5
11,0	9,7
4.810	4.810
12.330	11.370
65.670	62.540
57.430	55.030
4.640	5.255
2.450	2.235
4.640	4.760
9.680	9.875
67.900	71.700
165	160
645	610
107.200	107.350
14.490	14.685
11.000	11.200
9.200	9.200

### WA900-3

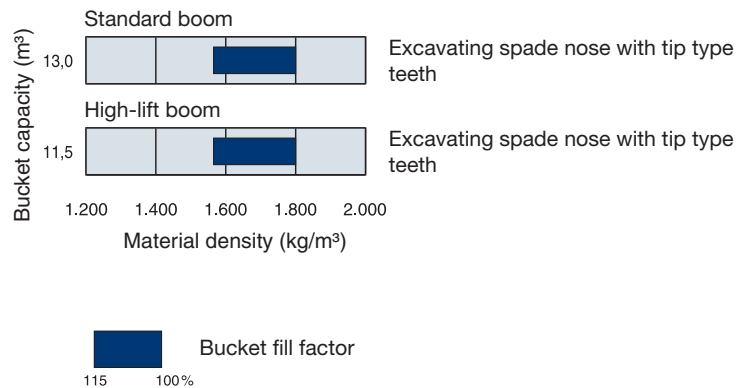

This guide, representing bucket sizes for general purpose applications, will help you select the proper bucket size for material density, loader configuration, and operating conditions. Optimum bucket size is determined after adding or subtracting all tipping load changes due to optional equipment. Bucket fill factors represent the approximate amount of material as a percent of rated bucket capacity. Fill factors are primarily affected by material, ground conditions, breakout force, bucket profile, and the cutting edge of the bucket used. For bench excavating bucket sizes, please contact your nearest Komatsu distributor for more information.

# WHEEL LOADER

## STANDARD EQUIPMENT

### Engine

- Komatsu SAA12V140E-3 engine, EPA Tier II compliant
- Alternator 90 A/24 V
- Batteries 160 Ah/12 V × 4
- Starter motor 7,5 kW/24 V × 2
- Water separator

### Cab

- ROPS/FOPS frame to SAE
- Air conditioner
- Electronic display/monitoring system (EDIMOS II)
- Air-suspended seat with seat belt
- Advanced Joystick Steering System (AJSS)
- Washer, front & rear
- Wiper, front & rear, front intermittent
- Rear-view mirrors
- Sun visor

### Powertrain

- Electronically controlled transmission (3F, 3R)
- Hydraulically activated oil cooled disc service brakes
- Dry disc parking brake
- Full-floating axles

### Hydraulics

- 2-spool main control valve
- Bucket positioner
- Automatic boom kick-out

### Machine

- Automatic shift control
- Active power-up system (two stage hydraulics)
- In-line filter
- Power train underguard

### Others

- Standard boom
- Counterweight (WA900-3)
- Corrosion resistor
- Front fenders
- Rear access stairs
- PM service connectors
- VHMS (Vehicle Health Monitoring System)

### Safety

- Back-up alarm
- Electric horn
- Emergency steering
- Emergency brake
- Rear under view mirror
- Side working light

### Tyres

- 45/65 R45 radial tyres

### Lights

- 2 front working lights
- 2 head lights
- Reverse lights
- Stop and tail lights
- Turn signal with hazard switch (2 front, 2 rear)

## OPTIONAL EQUIPMENT

### Engine

- Batteries 200 Ah (C200)
- Engine shut off mechanical
- Radiator core protection grid
- Radiator anti-clogging type

### Cab

- Tilttable steering wheel
- Joystick steering (in conjunction with steering wheel)
- Radio-cassette

### Tyres

- Rims for 45/65-45 tyres
- Bias and radial ply tyres
- Tyre inflation kit

### Buckets

- Special buckets on request

### Others

- Counterweight 1.600 kg (WA800-3)
- Satellite communication system for VHMS

### Machine

- Counterweight, additional (1.600 kg) for high-lift arrangement (WA800-3)
- Counterweight for high-lift arrangement (2.900 + 1.400 + 1.600 kg) (WA900-3)
- Fuel tank with fast fill coupler
- Auto greasing
- Boom for high-lift arrangement
- Boom for Load & Carry arrangement (WA800-3)
- Cold area arrangement (-30 °C to 40 °C)
- Remote boom positioner (WA800-3)

### Safety

- Fog lamp
- Fire extinguisher
- Beacon light



**Komatsu Europe  
International NV**

Mechelsesteenweg 586  
B-1800 VILVOORDE (BELGIUM)  
Tel. +32-2-255 24 11  
Fax +32-2-252 19 81  
www.komatsu.eu