

KOMATSU

PC600-8

PC600LC-8

ENGINE POWER
323 kW / 433 HP @ 1.800 rpm

OPERATING WEIGHT
PC600-8: 57.640 - 58.460 kg
PC600LC-8: 58.640 - 60.380 kg

BUCKET CAPACITY
max. 3,5 m³

PC
600

HYDRAULIC EXCAVATOR



PC600/LC-8

ecot3

WALK-AROUND

Productivity features

- **Large digging force**
High operating efficiency with large digging force at rugged work sites.
- **High work equipment speed**
Increased arm and bucket dumping speed means efficient loading.
- **Lifting mode**
The lifting mode increases the lifting force by 17%.
- **Two-mode setting for the boom**
Switch selection allows either powerful digging or smooth boom operation.
- **Large drawbar pull and steering force**
provide excellent mobility.
- **PowerMax function**
temporarily increases digging force by 8% for added power in tough situations.
- **Excellent swing performance**
provides excellent swing performance on slopes.

Excellent reliability and durability

- **Strengthened boom and arm**
with large cross-sections and reliable welding for maximum strength and reliability.
- **Face seals**
with excellent sealing performance are used for the hydraulic hoses.
- **Protected hydraulic circuit**
The cool-running hydraulic system is protected with the most extensive filtration system available, including a high pressure in-line filter for each main pump.
- **Sturdy guards**
shield the travel motors against damage from rocks.
- **Highly-reliable electronic devices**
Exclusively-designed electronic devices are certified by severe testing.
 - Controller • Sensors
 - Connectors • Heat-resistant wiring

Easy maintenance

- Reverse rotation function of fan allows easier cleaning of radiator
- Optimised engine checkpoint locations
- Easy detachable radiator and oil cooler

Safety

- Large handrail, step and catwalk provide easy access to the engine and hydraulic equipment.
- Extreme durable anti slip plates for safe access



Ecology and economy features

- Engine meets EU Stage IIIA emissions regulations
- Electronically controlled EGR system
- Reduced NOx emissions
- Variable speed electronic controlled fan
- Four level Economy mode allows optimum combination of fuel economy and production
- Meets EU Stage 2 noise regulations

Large, comfortable cab

- Low noise and vibration with cab damper mounting
- Large-capacity cab with narrow corner posts provides improved visibility
- Large-capacity air conditioner
- Pressurised cab prevents external dust from entering

Advanced monitor features

- Machine condition can be checked with Equipment Management Monitoring System (EMMS)
- Two working modes combine with lifting mode for maximum productivity

**ENGINE POWER**

323 kW / 433 HP @ 1.800 rpm

OPERATING WEIGHT

PC600-8:

57.640 - 58.460 kg

PC600LC-8:

58.640 - 60.380 kg

BUCKET CAPACITYmax. 3,5 m³

ecot3
ecology & economy - technology 3

New generation of Komatsu engines

WORKING ENVIRONMENT

PC600-8's cab interior is spacious and provides a comfortable working environment...

SpaceCab™

Superb visibility

The PC600-8's large capacity cab and increased glass area provide superb front visibility.

Cab mounts

The new cab damper mounting reduces vibrations and noise at operator's seat.

Standard heated air suspension seat

Low-noise design

The noise levels at the operator's ear have been decreased by improving the cab mounts and cab sealing performance.

Multi-position controls

The multi-position, proportional pressure control levers allow the operator to work in comfort while maintaining precise control. A double-slide mechanism allows the seat and controllers to move together or independently, allowing the operator to position the controllers for maximum productivity and comfort.

Pressurised cab

The optional air conditioner, air filter, and a higher internal air pressure (6 mm Aq) prevent external dust from entering the cab.

Automatic air conditioner

A 6.900 kcal air conditioner is utilised. The bi-level control function keeps the operator's head and feet cool and warm respectively. This improved air flow function keeps the inside of the cab comfortable throughout the year.



Seat with headrest fully reclined



SAFETY & MAINTENANCE FEATURES

Safety features



Rigid, safe operator's cab

- OPG top guard meets ISO 10262 Level 2 (optional)
- Additional head lamp
- Lower wiper (optional)



Pump/engine room partition

Prevents hydraulic oil from spraying onto the engine to reduce the risk of fire.



Step light with timer

Provides light for about one minute to allow the operator to get off the machine safely.



Large handrails and wide catwalk

Serrated steps and walkway, with highly durable anti slip plates give safer access.

Easy maintenance – Komatsu designed the PC600-8 for easy service access

Wide catwalk

A wide walkway for maintenance is provided around the engine and hydraulic components, allowing easy access to the inspection and maintenance points.

Footing over the engine

Because a step has been installed on a section above the engine, daily inspections of the engine and its surrounding area are easily conducted. Also, a protective cover has been installed to prevent direct hand contact with high temperature sections such as the turbocharger.

Reduced maintenance costs

The hydraulic oil filter replacement has been extended from 500 hours to 1000 hours. Check points are concentrated to one side of the engine for quick & easy access.

Anti-slip plates

Highly durable anti-slip plates maintain superior traction performance for the long term.

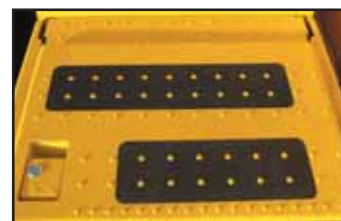

EMMS

Working mode selection

Hydraulics

A unique two-pump system assures smooth compound movement of the work equipment. The OLSS (Open Center Load Sensing System) controls all pumps for efficient use of engine power. This system also reduces hydraulic loss during operations.

Power and Economy mode

The PC600-8 excavator is equipped with two working modes. Each mode is designed to match the engine speed, pump speed, and system pressure to the current application, giving the operator the flexibility to match the equipment performance to the job at hand.

Working mode	Advantage
P Power mode	<ul style="list-style-type: none"> • Maximum production/power • Fast cycle times
E Economy mode (4 stage: E0, E1, E2, E3)	<ul style="list-style-type: none"> • Good cycle times • Good fuel economy
L Lifting mode	<ul style="list-style-type: none"> • Hydraulic pressure increased by 17%

Lifting mode

Gives the operator 17% more lifting force on the boom when needed, for handling rock or heavy lifting applications.

PowerMax function

This function temporarily increases the digging force by 8% for added power in tough situations.

Excellent underfoot digging performance

The operability of the underfoot area, just below the operators cab, is excellent. This makes grading, leveling, rolling, carrying, and scraping soil in the underfoot area easy.

Automatic two-speed travel

Travel speed is automatically shifted from high to low speed, according to the travel pressure.



Multi-function colour monitor

EMMS (Equipment Management Monitoring System)

- Monitor function: The controller monitors the engine oil level, coolant temperature, battery charge, air-filter restriction, and more. The controller finds any abnormality and displays it on the LCD.
- Maintenance records like engine oil replacement, hydraulic oil, filters and so on can be stored.
- The trouble data memory function stores machine abnormalities (error codes) in the monitor for effective troubleshooting.

Two settings for the boom

Smooth mode provides easy operation for gathering blasted rock and scraping operations. When maximum digging force is needed, switch to the power mode for more effective excavating.

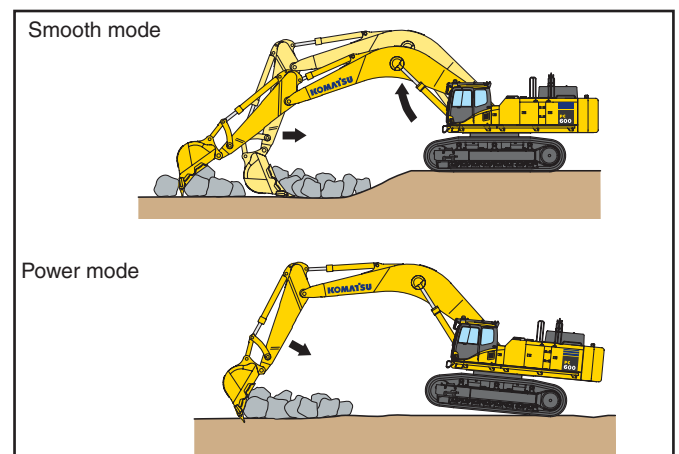

PRODUCTIVITY FEATURES

High production and low fuel consumption

Engine

The PC600-8 gets its exceptional power and work capacity from its Komatsu SAA6D140E-5 engine. The output is 323 kW (433 HP). Using an electronically controlled EGR system, the engine delivers high power with low fuel consumption and meets EU Stage IIIA emissions regulations.

Large digging force

Thanks to the high engine output and an excellent hydraulic system, this machine delivers a powerful digging force.

Large drawbar pull and steering force

Because the machine has a large drawbar pull and a substantial steering force, it provides excellent mobility, even when working on an incline.

Excellent swing performance

The twin-swing motor system of PC600-8 provides excellent swing performance on slopes.

Excellent machine stability

The substantial machine weight and wide track gauge provide excellent machine stability.

Electronically controlled variable speed fan

The fan speed is electronically controlled according to actual operating conditions, ensuring maximum deployment of engine power to working, while minimising noise.

4-stage Economy mode

allows optimum combination of economy and production.

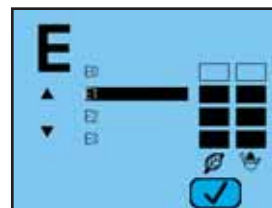

DURABILITY & RELIABILITY

Excellent reliability and durability

Strengthened boom and arm

Thanks to the large cross-sectional structure employing a high tensile strength steel with a thick plate, partition wall, etc., the boom and arm provide excellent durability and are highly resistant to bending and twisting.

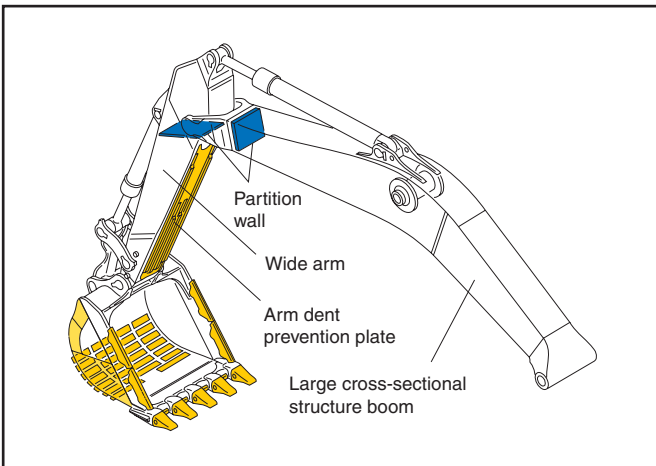

O-ring face seals

The hydraulic hose seal method has been changed from a conventional taper seal to an O-ring seal. This provides improved sealing performance during vibration.

Frame structure

The revolving frame and centre frame mount have no welding structure. This ensures that force is transmitted directly to the thick plate of the frame without passing through any welds.

High-pressure In-Line filtration

The PC600-8 has the most extensive filtration system available, providing in-line filters as standard equipment. An in-line filter in the outlet port of each main hydraulic pump reduces failure caused by contamination.



Metal guard rings

Metal guard rings protect all of the hydraulic cylinders, and improve reliability.

Heat-resistant wiring

Heat-resistant wiring is utilised for the engine's electric circuit and other major component circuits.

Sturdy undercarriage

The undercarriage is strengthened to provide excellent reliability and durability when working on rocky ground or blasted rock.



Sturdy guards

shield the travel motors and piping against damage from rocks



Track roller guard (full length)
supplied as standard equipment

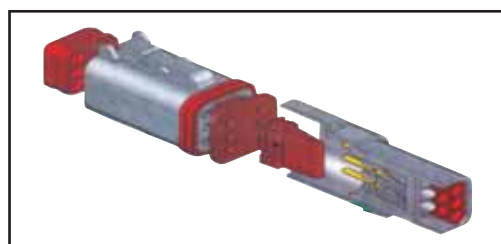

DT-type connectors
seal tight and have higher reliability

KOMTRAX™ - KOMATSU TRACKING SYSTEM



The Komatsu Tracking System, KOMTRAX™, provides a revolutionary new way to monitor your equipment, any-time, anywhere. It lets you pin-point the precise location of your machines and obtain real-time machine data. Using GPS transmitter and satellite technology, it's designed to be future proof and will meet your demands today and tomorrow.



KOMTRAX™ server

Check machine location



Customer



Check service meter



Monthly-yearly record

A screenshot of the software interface for viewing monthly and yearly records. It shows a detailed table with columns for dates, machine status, and various performance metrics.

Service & maintenance record

A screenshot of the software interface for service and maintenance records. It displays a table with columns for maintenance type, date, and status, providing a comprehensive log of machine servicing.

Working levels (fuel, hrs etc)

A screenshot of the software interface for working levels. It shows a table with columns for fuel levels, water temperature, and other operational metrics, along with a bar chart for visual representation.

There are certain countries where KOMTRAX™ is not yet available, please contact your distributor when you want to activate the system. Komtrax will not operate if the satellite signal is blocked or obscured.

SPECIFICATIONS



ENGINE

Model..... Komatsu SAA6D140E-5
 Type..... Common rail direct injection, water-cooled, emissionised, turbocharged, after-cooled diesel
 Engine power
 at rated engine speed 1.800 rpm
 ISO 14396.....323 kW / 433 HP
 ISO 9249 (net engine power).....320 kW / 429 HP
 No. of cylinders 6
 Bore x stroke 140 x 165 mm
 Displacement..... 15,24 ltr
 Governor..... All-speed, electronic



HYDRAULIC SYSTEM

Type..... Open-center load-sensing system
 Number of selectable working modes 2
 Main pump..... Variable-capacity piston pump
 Pumps for Boom, arm, bucket, swing, and travel circuits
 Maximum pump flow..... 2 x 410 ltr/min
 Supply for control circuit Gear pump
 Hydraulic motors:
 Travel..... 2 x axial piston motor with parking brake
 Swing 2 x axial piston motor with swing holding brake
 Relief valve settings:
 Standard 325 kg/cm²
 Travel circuit 350 kg/cm²
 Swing circuit..... 260 kg/cm²
 Lifting circuit..... 350 kg/cm²
 Pilot circuit..... 30 kg/cm²
 Hydraulic cylinders (No. of cylinders – bore x stroke):
 Boom..... 2 – 185 mm x 1.725 mm
 Arm 1 – 200 mm x 2.045 mm
 Bucket (for 3,5 m arm) 1 – 185 mm x 1.425 mm
 Bucket (for 2,9 m arm) 1 – 185 mm x 1.610 mm



ENVIRONMENT

Engine emissions Fully complies with EU Stage IIIA and EPA Tier III exhaust emission regulations
 Noise levels
 LwA external 108 dB(A) (2000/14/EC Stage II)
 LpA operator ear 75 dB(A) (ISO 6396 dynamic test)



OPERATING WEIGHT (APPR.)

Operating weight, including 6.600 mm one-piece boom, 2.900 mm arm, 2.500 kg backhoe bucket, operator, lubricant, coolant, full fuel tank and the standard equipment.

MONO BOOM	PC600-8		PC600LC-8	
	Operating weight	Ground pressure	Operating weight	Ground pressure
Triple grouser shoes				
600 mm	57.640 kg	1,03 kg/cm ²	58.640 kg	0,98 kg/cm ²
750 mm	58.460 kg	0,84 kg/cm ²	59.520 kg	0,79 kg/cm ²
900 mm	–	–	60.380 kg	0,67 kg/cm ²



SWING SYSTEM

Type Hydraulic motor
 Swing reduction Planetary gear
 Swing circle lubrication Grease-bathed
 Swing lock Oil disc brake
 Swing speed 8,3 rpm



DRIVES AND BRAKES

Steering control 2 levers with pedals
 Drive method Hydrostatic
 Travel motor Axial piston motor, in-shoe design
 Reduction system Planetary double reduction
 Max. drawbar pull 42.300 kg
 Gradeability 70%
 Max. travel speeds
 Lo / Hi..... 3,0 / 4,9 km/h
 Service brake..... Hydraulic lock
 Parking brake..... Oil disc brake



UNDERCARRIAGE

Construction H-leg frame
 with box section track-frames
 Track assembly
 Type..... Fully sealed
 Shoes (each side) 49 (PC600), 52 (PC600LC)
 Tension..... Hydraulic
 Rollers
 Track rollers (each side) 8 (PC600), 9 (PC600LC)
 Carrier rollers (each side) 3



COOLANT AND LUBRICANT CAPACITY (REFILLING)

Fuel tank..... 880 ltr
 Radiator 58 ltr
 Engine oil..... 40 ltr
 Swing drive (2)..... 13 ltr
 Hydraulic tank..... 360 ltr
 Final drive (each side) 10 ltr

MACHINE DIMENSIONS

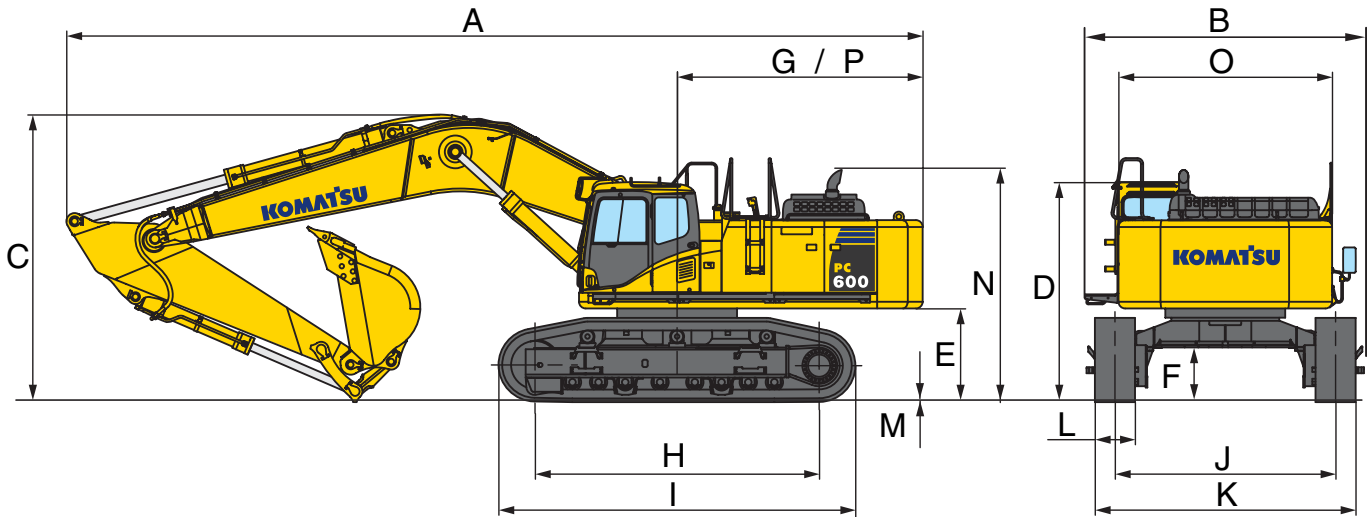

BOOM LENGTH		7.660 mm	6.600 mm	7.300 mm
ARM LENGTH		3.500 mm	2.900 mm	3.500 mm
A	Overall length	12.810 mm	11.830 mm	12.440 mm
B	Overall width	4.210 mm	4.210 mm	4.210 mm
C	Overall height (to top of boom)	4.300 mm	4.600 mm	4.280 mm
D	Overall height (to top of cab)	3.290 mm	3.290 mm	3.290 mm
E	Clearance under counterweight	1.365 mm	1.365 mm	1.365 mm
F	Minimum ground clearance	780 mm	780 mm	780 mm
G	Tail swing radius	3.800 mm	3.800 mm	3.800 mm
H	Track length on ground	4.600 mm	4.250 mm	4.250 mm
I	Track length	5.690 mm	5.340 mm	5.340 mm
J	Track gauge	2.590 mm	2.590 mm	2.590 mm
	Track gauge at expanded position	3.300 mm	3.300 mm	3.300 mm
K	Width of crawler	3.900 mm	3.900 mm	3.900 mm
	Width of crawler (when retracted)	3.190 mm	3.190 mm	3.190 mm
L	Track shoe width	600 mm	600 mm	600 mm
M	Grouser height	37 mm	37 mm	37 mm
N	Machine cab height	3.435 mm	3.435 mm	3.435 mm
O	Machine cab width	3.195 mm	3.195 mm	3.195 mm
P	Distance, swing center to rear end	3.675 mm	3.675 mm	3.675 mm

BUCKET AND ARM FORCE (ISO)		
Arm length	3.500 mm	2.900 mm
Bucket digging force	30.000 kg	34.300 kg
Bucket digging force at PowerMax	32.300 kg	36.900 kg
Arm crowd force	23.300 kg	27.700 kg
Arm crowd force at PowerMax	25.100 kg	29.900 kg

DIMENSIONS

UPPER STRUCTURE + UNDERCARRIAGE

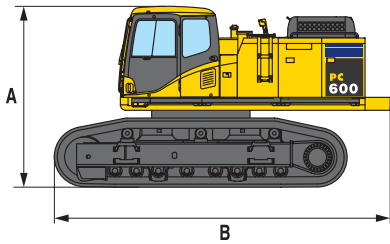

	PC600-8	PC600LC-8
Overall width	3.195 mm	3.195 mm
A	3.330 mm	3.330 mm
B	6.170 mm	6.340 mm
Weight	34.240 kg	35.240 kg

UNDERCARRIAGE

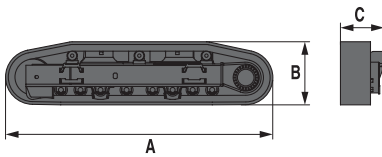

	PC600-8	PC600LC-8
A	5.340 mm	5.690 mm
B	1.260 mm	1.260 mm
C	875 mm	875 mm
Weight	16.400 kg	17.400 kg

WORK EQUIPMENT

Boom

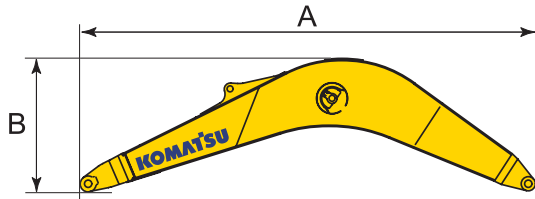

Arm

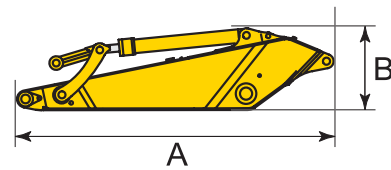

BOOM	6.600 mm	7.300 mm	7.600 mm
Overall width	1.190 mm	1.190 mm	1.190 mm
A	6.870 mm	7.545 mm	7.925 mm
B	2.095 mm	1.960 mm	2.040 mm
Weight (incl. arm cylinder)	5.300 kg	5.300 kg	5.400 kg

ARM	2.900 mm	3.500 mm
Overall width	480 mm	480 mm
A	4.285 mm	4.885 mm
B	1.430 mm	1.240 mm
Weight (incl. bucket cylinder & linkage)	3.400 kg	3.300 kg

COUNTERWEIGHT

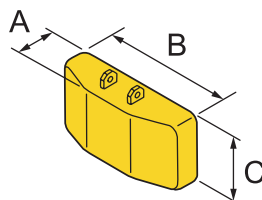

COUNTERWEIGHT	
A	680 mm
B	3.195 mm
C	1.330 mm
Weight	10.750 kg

CYLINDERS

Boom & arm cylinders

BOOM & ARM CYLINDERS	
Weight	1.800 kg

WORKING RANGE

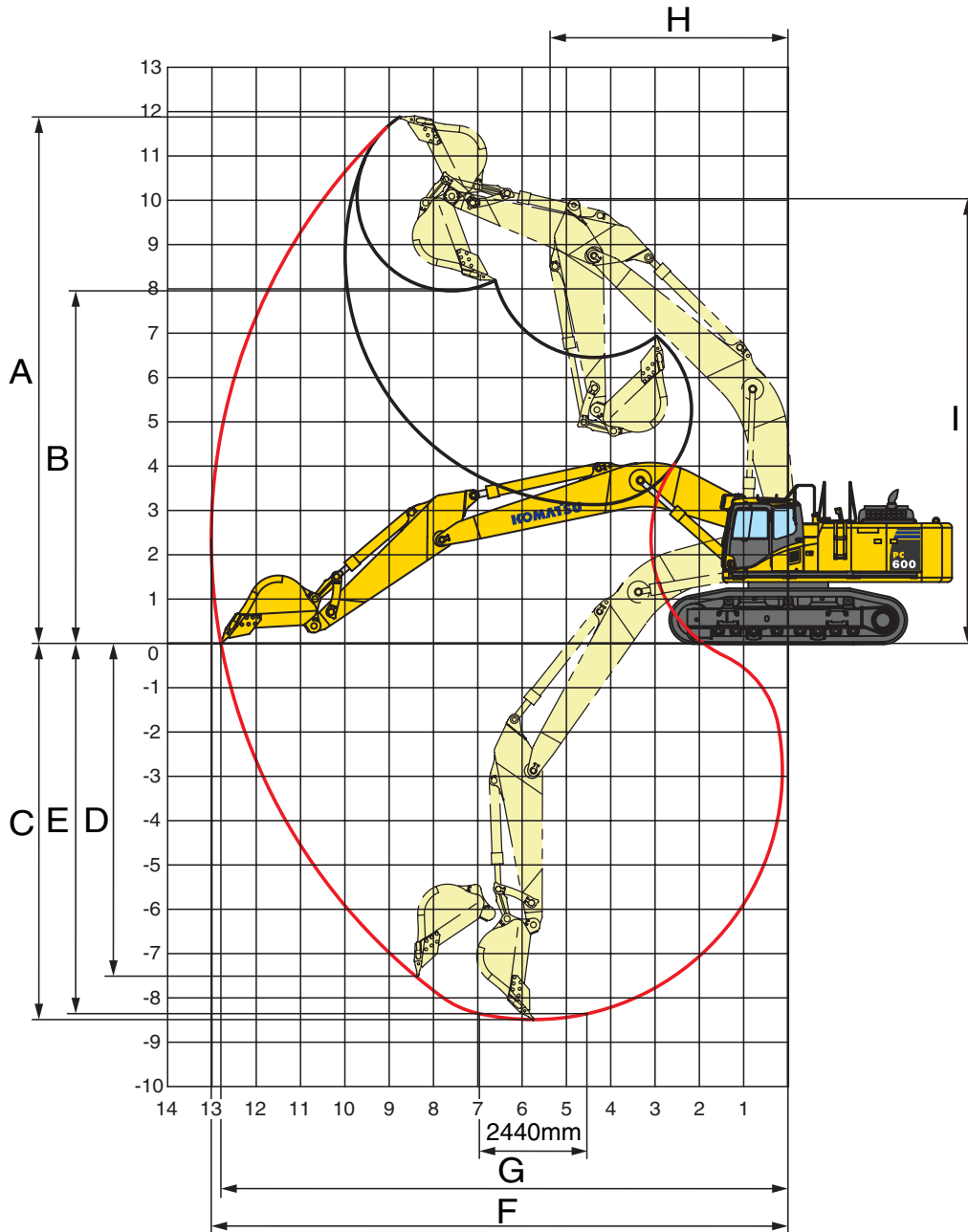

BOOM LENGTH		7.660 mm	6.600 mm	7.300 mm
ARM LENGTH		3.500 mm	2.900 mm	3.500 mm
A	Max. digging height	11.880 mm	11.140 mm	11.475 mm
B	Max. dumping height	7.960 mm	7.210 mm	7.650 mm
C	Max. digging depth	8.490 mm	7.060 mm	8.165 mm
D	Max. vertical wall digging depth	7.510 mm	5.630 mm	6.660 mm
E	Max. digging depth of cut for 2,44 m level	8.360 mm	6.910 mm	8.030 mm
F	Max. digging reach	13.020 mm	11.550 mm	12.615 mm
G	Max. digging reach at ground level	12.800 mm	11.300 mm	12.385 mm
H	Min. swing radius	5.370 mm	4.670 mm	5.090 mm
I	Max. height of min. swing radius	10.020 mm	9.300 mm	9.745 mm

LIFTING CAPACITY

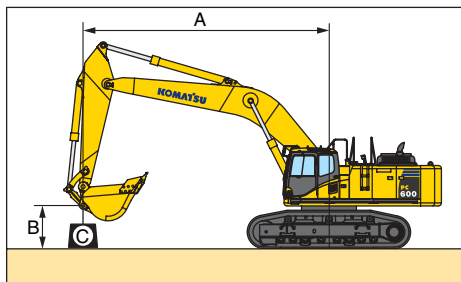

- A – Reach from swing centre
- B – Bucket hook height
- C – Lifting capacities

- Rating over front
- Rating over side
- Rating at maximum reach

Arm length	A			9,1 m		7,6 m		6,1 m		4,6 m		3,0 m	

PC600-8

L Mode: OFF

Boom: 7.300 mm With 600 mm shoes	9,1 m	kg	*6.500	*6.500										
	6,1 m	kg	*6.350	*6.350	*9.650	9.300	*10.700	*10.700						
	3,0 m	kg	*7.150	6.200	*11.000	8.600	*13.200	11.950	*16.900	*16.900	*24.200	*24.200		
	0,0 m	kg	8.400	6.150	10.700	7.950	14.500	10.750	*19.600	15.400	*21.300	*21.300		
	-3,0 m	kg	10.300	7.600	10.550	7.850	*14.100	10.500	*18.250	15.150	*24.150	*24.150	*21.900	*21.900
	-6,1 m	kg	*9.500	*9.500										

L Mode: ON

Boom: 7.300 mm With 600 mm shoes	9,1 m	kg	*8.150	*8.150										
	6,1 m	kg	*7.950	7.450	12.150	9.300	*13.450	13.350						
	3,0 m	kg	8.350	6.200	11.400	8.600	15.700	11.950	*21.000	17.400	*29.850	27.900		
	0,0 m	kg	8.400	6.150	10.700	7.950	14.500	10.750	20.950	15.400	*25.450	24.800		
	-3,0 m	kg	10.300	7.600	10.550	7.850	14.200	10.500	20.650	15.150	*30.200	24.900	*26.150	*26.150
	-6,1 m	kg	*12.450	*12.450										

L Mode: OFF

Boom: 6.600 mm With 600 mm shoes	9,1 m	kg	*9.700	*9.700										
	6,1 m	kg	*8.950	*8.950			*11.950	*11.950						
	3,0 m	kg	*9.800	7.600	11.400	8.600	*14.000	12.000	*17.650	17.600	*24.700	*24.700		
	0,0 m	kg	10.300	7.650	10.850	8.050	14.700	10.950	*19.900	15.700	*27.600	25.250		
	-3,0 m	kg	*11.500	10.050			*12.850	10.900	*16.800	14.950	*22.950	*22.950	*30.500	*30.500
	-4,6 m	kg	*10.650	*10.650										

L Mode: ON

Boom: 6.600 mm With 600 mm shoes	9,1 m	kg	*11.850	*11.850										
	6,1 m	kg	*10.950	9.400			*14.950	13.200						
	3,0 m	kg	10.150	7.600	11.400	8.600	15.800	12.000	*21.850	17.600	*30.400	28.400		
	0,0 m	kg	10.300	7.650	10.850	8.050	14.700	10.950	21.300	15.700	*34.200	25.250		
	-3,0 m	kg	13.450	10.050			14.650	10.900	20.450	14.950	*28.700	25.500	*36.700	*36.700
	-4,6 m	kg	*13.800	13.750										

* Load is limited by hydraulic capacity rather than tipping. Ratings are based on SAE Standard No. J/ISO 10567. Rated loads do not exceed 87% of hydraulic lift capacity or 75% of tipping load.

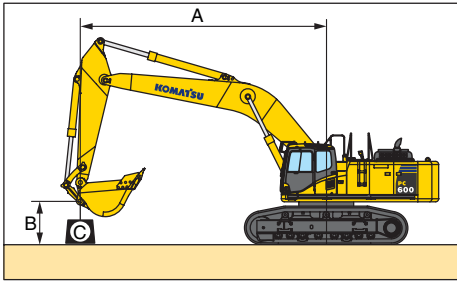

- A – Reach from swing centre
- B – Bucket hook height
- C – Lifting capacities

- Rating over front
- Rating over side
- Rating at maximum reach

Arm length	A			9,1 m		7,6 m		6,1 m		4,6 m		3,0 m	

PC600LC-8

L Mode: OFF

Boom: 7.660 mm	9,1 m	kg	*6.950											
	6,1 m	kg	*6.850	*6.850	*9.800	*9.800	*10.950	*10.950						
	3,0 m	kg	*7.550	6.200	*11.200	9.050	*13.500	12.350	*17.100	*17.100				
With 600 mm shoes	0,0 m	kg	9.350	6.150	*12.250	8.350	*15.100	11.050	*19.850	15.750	*16.550	*16.550		
	-3,0 m	kg	*10.150	7.400	*11.400	8.200	*14.350	10.750	*18.550	15.550	*24.150	*24.150	*19.450	*19.450
	-6,1 m	kg	*9.550	*9.550					*11.950	*11.950	*15.700	*15.700		

L Mode: ON

Boom: 7.660 mm	9,1 m	kg	*8.600											
	6,1 m	kg	*8.450	7.350	*12.350	9.850	*13.650	*13.650						
	3,0 m	kg	*9.300	6.200	13.300	9.050	*16.850	12.350	*21.300	17.350				
With 600 mm shoes	0,0 m	kg	9.350	6.150	12.550	8.350	16.700	11.050	24.350	15.750	*19.800	*19.800		
	-3,0 m	kg	*11.200	7.400	12.400	8.200	16.400	10.750	*23.200	15.550	*30.150	25.400	*23.200	*23.200
	-6,1 m	kg	*12.400	*12.400					*15.400	*15.400	*20.100	*20.100		

* Load is limited by hydraulic capacity rather than tipping. Ratings are based on SAE Standard No. J/ISO 10567. Rated loads do not exceed 87% of hydraulic lift capacity or 75% of tipping load.

Bucket, arm and boom combinations

MODEL	PC600LC-8		PC600-8			Bucket width (recommended)	
	7.660 mm	7.660 mm	7.300 mm	7.300 mm	6.600 mm	Excl. side cutter (side shroud)	Incl. side cutter (side shroud)
Arm	3.500 mm	2.900 mm	3.500 mm	2.900 mm	2.900 mm		
Bucket 2,4 m ³	□	□	□	□	□	1.320 mm	1.400 mm
Bucket 2,7 m ³	○	□	□	□	□	1.600 mm	1.680 mm
Bucket 2,8 m ³	△	○	○	○	□	1.655 mm	1.705 mm
Bucket 3,5 m ³	△	△	△	△	○	1.850 mm	1.900 mm

- Recommended
- Possible to use
- △ Not available

HYDRAULIC EXCAVATOR

STANDARD EQUIPMENT

- Komatsu SAA6D140E-5, 323 kW turbocharged common rail direct injection diesel engine, EU Stage IIIA compliant
- Double element type air cleaner with dust indicator and auto-dust evacuator
- Cooling fan: remote hydraulically driven variable speed, reversible
- Radiator & oil cooler with fly net
- Automatic fuel line de-aeration
- Alternator 24 V/75 A
- Batteries 2 × 12 V/170 Ah
- Starter motor 24 V/11 kW
- Electronic Open-centre load sensing (E-OLSS) hydraulic system
- Auto-deceleration function
- Automatic engine warm-up system
- Engine overheat prevention system
- Multi-function colour monitor with equipment management monitoring system (EMMS)
- Working mode selection system (power mode, economy mode, lifting mode)
- Pump and engine mutual control (PEMC) system
- Adjustable PPC wrist control levers with 3 button controls for arm, boom, bucket and swing
- PPC control levers and pedals for steering and travel
- In-Line filter for hydraulics
- PowerMax function
- Hydrostatic, 2-speed travel system with automatic shift and planetary triple reduction final drives, and hydraulic travel and oil disc parking brakes
- SpaceCab™; highly pressurised and tightly sealed viscous mounted cab with tinted safety glass windows, opening roof hatch with window pull-up type front window with locking device, removable lower window, front window wiper with intermittent feature, ashtray, luggage box, floor mat, cigarette lighter, sun roller blind, bottle holder & magazine rack
- Air conditioning
- Stereo radio cassette
- Step light with timer
- 12 Volt power supply
- Fully adjustable heated air suspension seat
- Track frame undercovers
- Beacon
- Additional cab roof lights
- Machine cab handrails and catwalk
- Remote greasing for swing circle and pins
- Lockable fuel cap and covers
- Full length track roller guards
- Parts book and operator manual
- Engine ignition can be password secured on request
- Standard colour scheme and decals
- 2 mode boom control
- Counterweight mirror
- KOMTRAX™ Komatsu Tracking System
- Audible travel alarm
- Toolkit and spare parts for first service

OPTIONAL EQUIPMENT

- Shoes:**
 - 600 mm triple grousers
 - 750 mm triple grousers
 - 900 mm triple grousers
 - 600 mm double grousers
- Arms:**
 - 2.900 mm
 - 3.500 mm (not available with 6.600 mm boom)
- Booms:**
 - 6.600 mm (w/o boom safety valves)
 - 7.300 mm (with boom safety valves)
 - 7.660 mm (with boom safety valves)
- HCU for breaker (only with 7.300 mm and 7.660 mm boom)
- Arm safety valve (only with 7.300 mm and 7.660 mm boom)
- Rain visor
- Bio oil
- OPG Level II top guard (FOPS)
- OPG Level II front guard (FOPS)
- Lower wiper
- Auto grease system



Komatsu Europe International NV
 Mechelsesteenweg 586
 B-1800 VILVOORDE (BELGIUM)
 Tel. +32-2-255 24 11
 Fax +32-2-252 19 81
 www.komatsueurope.com